

A

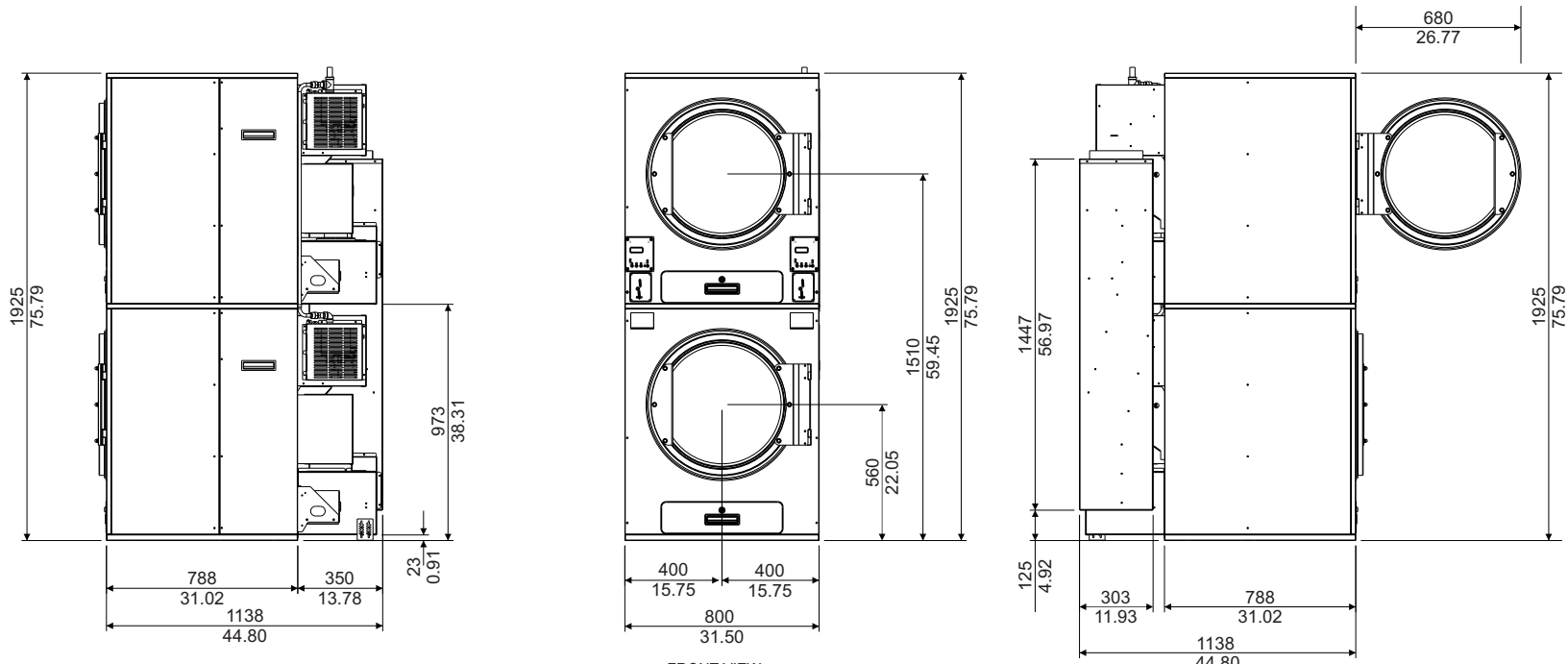

FRONT VIEW

LEFT VIEW

TOP VIEW

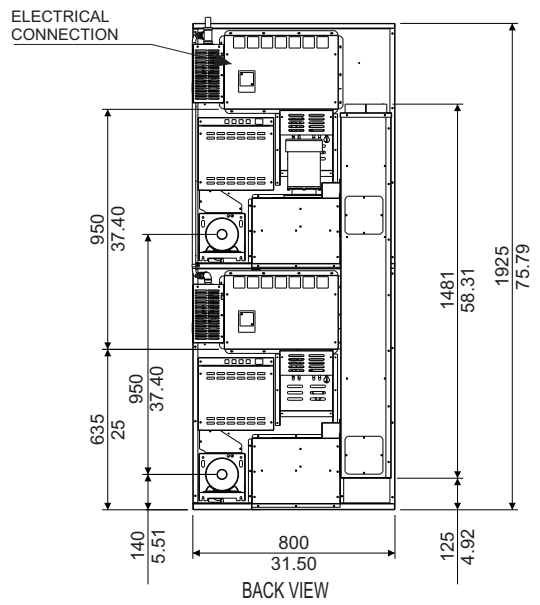

BACK VIEW

DE-235	Metric	USA		
Capacity - per pocket	kg	lbs	15.87	35
Dimensions				
A - Width	mm	in	800	31.50
B - Depth	mm	in	1138	44.80
C - Height	mm	in	1925	75.79
Drying Cylinder				
Diameter	mm	in	770	30.31
Depth	mm	in	688	27.09
Volume	liters	cu ft	320	11.31
Drive Information				
Cylinder motor	kW	HP	0.18	0.25
Blower motor	kW	HP	0.37	0.5
Gas Heat				
Airflow - per pocket	cu m/min	CFM	17	600
Gas consumption - per pocket	kcal/hr	BTU/hr	40662	161360
Gas inlet size	NPT		1/2	
Exhaust connection	mm	in	190	7.5
Electrical, 208-230VAC, 3PH	Breaker	FLA	10	3.15
Electrical, 440-460VAC, 3PH	Breaker	FLA	10	1.8
Electrical, 208-230VAC, 1PH	Breaker	FLA	10	7
Electrical, 120VAC, 1PH	Breaker	FLA	15	11
Net weight	kg	lbs	290	640
Shipping weight	kg	lbs	310	685
Electric Heat				
Airflow - per pocket	cu m/min	CFM	17	600
Electric consumption	kW		22	
Exhaust connection	mm	in	190	7.5
Electrical, 208-230VAC, 3PH	Breaker	FLA	80	67
Electrical, 440-460VAC, 3PH	Breaker	FLA	40	34
Net weight	kg	lbs	285	628
Shipping weight	kg	lbs	310	685

REV	BY	DATE	REV. DESCRIPTION
A1	AFA	12-9-2022	Created
DRAWN BY		DATE	 Panama City Beach, FL Phone: 850-249-2222 Fax: 850-249-2226 www.bandtech.com
A. Adcock		12-9-2022	
CHECKED BY		DATE	
P. Noblit		12-9-2022	
DESCRIPTION			
General Technical Specifications DE-235 Stack Dryer			
DATE	FILE NAME	SHEET	
12-9-2022	DE-235-General-Specifications.cdr	1 OF 1	